

Serie Steel

40T

Cable Chains in Bright Zinc Plated Steel

Inner height (D) 112,5 mm

Double share link construction.
Triple-ribose fixing and standard large washer and nylon anti-friction disk to assure smooth and durable movement.
Un-screwable Alu-draw frames (T) are standard mounted and every link.
Alu-drilled plates (TL) are mounted every second link with an Alu-draw frames every other link.
Separator systems available.
Also available in Stainless Steel.

Technical characteristics when self-supported

Speed	0,5 m/s
Acceleration	2 m/s ²

For higher requirements please consult our technical dept.

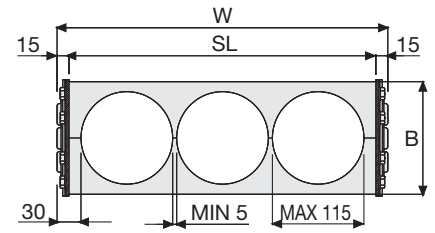
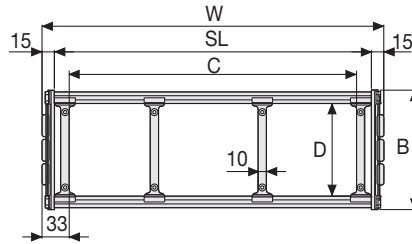

Separator

- Unassembled Part.no S310TCF9
- Assembled Part.no S310TCF9MC

Aluminium Draw Plates with Separators in Nylon

W	B	C	D	R	Weight/m	Chain
mm	mm	mm	mm	mm	kg	Part Number
216	145	150	112,5	250-300-350-400-450-500-550-600-700-750-850-1000	20,72	40T150□□□□*
266	145	200	112,5	250-300-350-400-450-500-550-600-700-750-850-1000	21,18	40T200□□□□*
316	145	250	112,5	250-300-350-400-450-500-550-600-700-750-850-1000	21,64	40T250□□□□*
366	145	300	112,5	250-300-350-400-450-500-550-600-700-750-850-1000	22,10	40T300□□□□*
466	145	400	112,5	250-300-350-400-450-500-550-600-700-750-850-1000	23,02	40T400□□□□*
566	145	500	112,5	250-300-350-400-450-500-550-600-700-750-850-1000	23,95	40T500□□□□*
C+66	145	112,5	250-300-350-400-450-500-550-600-700-750-850-1000		40T□□□□□□**

*Complete the code by inserting the value of the radius (R): Ex. 40T150 [2] [3] [4]

**Complete the code by inserting the value of the quote C and the radius (R): Ex. 40T [1] [2] [3] [4] [5] [6]

Aluminium Split Cross Piece Created by Design

W	B	R	Chain
mm	mm	mm	Part Number
SL+30	145	250-300-350-400-450-500-550-600-700-750-850-1000	40TL □□□□□□***

***Complete the code by inserting the value SL and the radius (R): Ex. 40TL [1] [2] [3] [4] [5] [6]

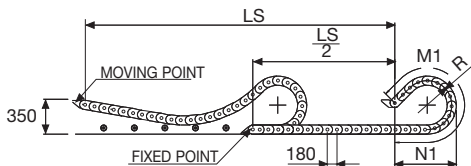
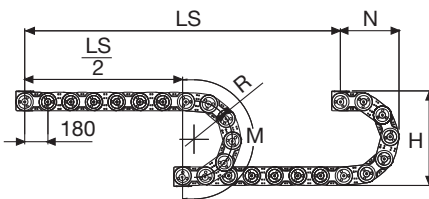

Length of chain (L)
Half travel distance ($\frac{LS}{2}$)
plus length of curve (M)

$$L = \frac{LS}{2} + M \text{ or } M1$$

R	H*	N	M	N1	M1
mm	mm	mm	mm	mm	mm
250	670	510	1150	1545	3285
300	770	555	1305	1755	3790
350	870	605	1460	1950	4265
400	970	655	1620	2125	4715
450	1070	710	1780	2295	5150
500	1170	755	1930	2455	5570
550	1270	805	2090	2605	5975
600	1370	855	2245	2755	6375
700	1570	955	2560	3035	7155
750	1670	1010	2720	3170	7535
850	1870	1105	3030	3430	8280
1000	2170	1255	3500	-	-

* The height H should be increased by 10 mm/m approx. because of preload. In case of limitation to the available space, refer to the Technical Dptm.



Self-Supporting Capacity Diagram

The maximum length of the self-supporting capacity ($\frac{LS}{2}$) in relationship to the weight of the cables and hoses contained per linear metre.

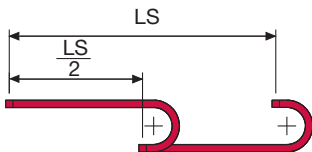
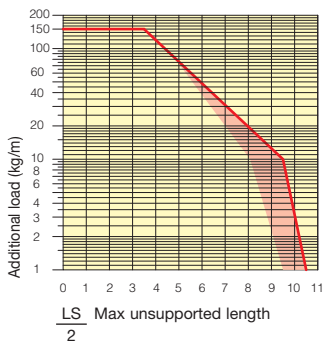

The red marking in the diagram area considers the difference of weight between various widths of chains assembled with aluminium draw plates every second pitch.

For applications with $\frac{LS}{2}$ and weights not included in the area of the diagram showing self-supporting capacity, verify the possible use of support rollers (see page 30).

Bright Zinc Plated Steel End Brackets

The end brackets set, containing four steel plates screwed to the links allows the two ends of the chain to be attached to the equipment.

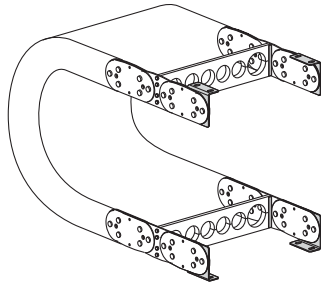
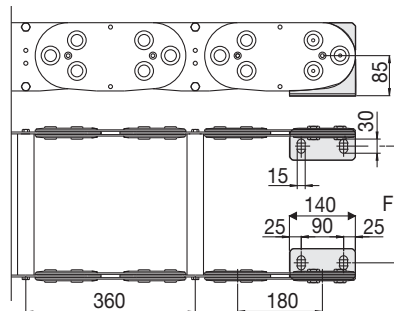

Fig. A
Chain fixed outside the radius. (Fig A)
See end brackets mounting variations page 31.



Chain Type	F mm
40T150	136
40T200	186
40T250	236
40T300	286
40T400	386
40T500	486

Special widths F=W-80

Bright Zinc Plated Steel Type Part Numbers

Complete Set Assembled	
Chain Type	End Brackets Set
40...	A4000KM □**

Complete Set Unassembled	
Chain Type	End Brackets Set
40...	A4000K

** 1=Pos.1; 2=Pos.2; 3=Pos.3
See end brackets mounting variations page 31.

Serie Steel

40T Cable Chain in Bright Zinc Plated Steel



Suitable to long travel distance.
See page 215

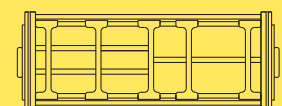

Supplementary movable separators.

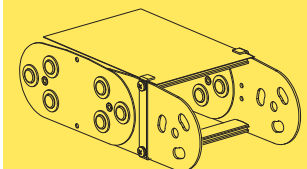

Steel laminar cover.

For further information please consult Brevetti Stendalto's Technical Office